



Planning & Development Services

Boise City Hall, 2nd Floor
150 N. Capitol Boulevard
P. O. Box 500
Boise, Idaho 83701-0500

Phone: 208/384-3830
Fax: 208/384-3753
TDD/TTY: 800/377-3529
Website: www.cityofboise.org/pds

MEMORANDUM

TO: Boise City Council

FROM: David Abo, AICP, Subdivision Review Analyst
Boise City Planning and Development Services

HEARING DATE: November 19, 2013

RE: SUB13-00040 / 8th & Main Condominiums /Prelim./Final Plat

8th & Main LLC is requesting preliminary/final plat approval of a 20-story, mixed-use building to include retail, restaurant, structured parking and offices. The condominium project includes 22 units and one common lot on a .60 acre parcel. The subject property is located on the northwest corner of North 8th Street and West Main Street.

On October 22, 2013, the Boise City Planning and Zoning Commission recommended approval of the Preliminary and Final plats of the OSL Depot Condominiums (SUB13-00032) subject to recommended Conditions of Approval. The Commission finds that the plat design and layout is in conformance with the goals, policies and objectives of the Boise City Comprehensive Plan and complies with the requirements of the Boise City Zoning Ordinance.

<u>Table of Contents</u>	Page
1. Property Information	2
2. Project Overview/Background	2
3. Zoning Ordinance	3
4. Transportation and Public Services	3
5. Comprehensive Plan	5
6. Recommendation	5
7. Recommended Conditions of Approval	5
<u>Maps</u>	
Vicinity Map	6
Preliminary /Final Plat	7
Aerial Map	18
<u>Agency Comments and Requirements</u>	
Boise City Public Works Department	19
Ada County Highway District	23
Boise City Fire Department	31

1. Property Information

Project Data	
Applicant/Status	8 th & Main LLC
Representative	Geoffrey Wardle
Location of Property	800 West Main Street
Size of Property	.60 acre
Zoning	C-5DD
Comprehensive Plan Designation	Downtown Mixed Use
Planning Area	Downtown Central Business District
Procedure	The Planning and Zoning Commission is the recommending body to City Council on a condominium plat.

2. Project Overview/Background

The condominium project is comprised of the Eighth & Main highrise project on the northwest corner of West Main Street and S. 8th Street as shown in the context photo below.

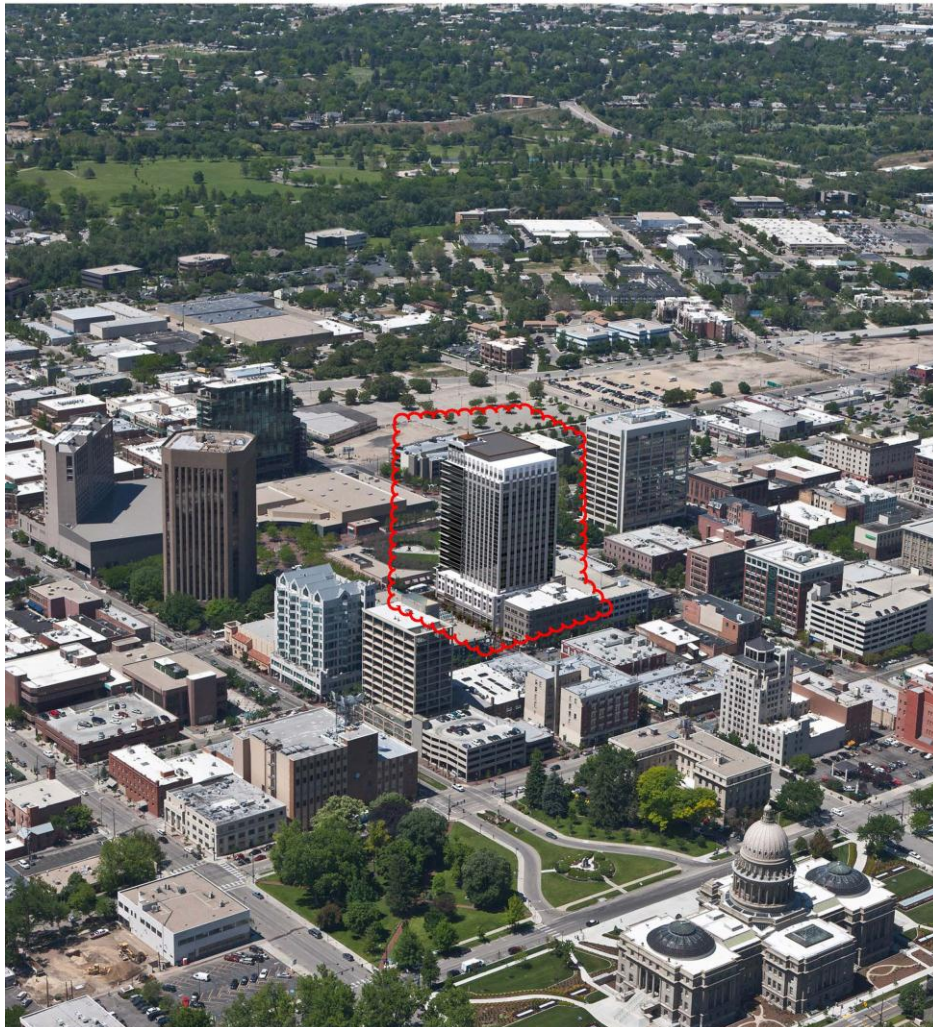

Land Use

The site is in the downtown core of Boise City. This area is mixture of uses and building styles. The structure to the north is listed on the historic register. The structure to the south is an office tower with below grade parking. To the west is the Eastman parking structure with retail on the bottom floor. To the east is the Captial Terrace Condominium businesses. These retail and restaurant businesses are located in cast-in-place concrete structures.

Adjacent Land Uses and Zoning

North:	Four story office/retail, C-5DD
South:	Twelve story office building and Grove, C-5DD
East:	Two story retail building, C-5DD
West:	Four story parking garage with ground level retail, C-5DD

3. Zoning Ordinance

Section	Description
11-03-04.4.	Subdivision Plat
11-03-04.4.B.(2).	Condominiums
11-09-01.	Purpose and Applicability
11-09-04.	Required Improvements

The existing building was previously approved by the Design Review Committee under DRH11-00124 and modified by DRH12-00233. it is a 20-story building with retail/restaurant uses on the first and second floor. The third through fifth floors are parking. Floors 6 through 19 are open floor plates for housing of office space.

The proposed condominium plat meets the requirements of Chapter 15, Title 55, Idaho Code as required by B.C.C. 11-03-04.4.B.(2)(a).

4. Transportation and Public Services

Traffic Count is based on vehicles per hour (VPH) in the PM Peak Hour

Roadway	Frontage	Functional Class	PM Peak Hour Traffic Count	PM Peak Hour Level of Service
Main Street One-Way	135 feet	Minor Arterial	709	Better Than "D"
8th Street	175 feet	Private	N/A	N/A

Trip Generation: The trip generation for this site is unknown at this time. ACHD Staff estimate that this site will generate 5,000 to 6,000 additional vehicle trips per day with 500 to 600 trips in the PM peak hour.

The Ada County Highway District is recommending approval of the condominium project subject to conditions of approval for the associated Design Review Application (DRH11-00240) approved on December 7, 2011 (see attached).

The site will be served by the municipal sewer and all public utilities are available to the site. The applicant must meet the requirements of the Boise City Public Works Department and the Boise City Fire Department.

5. Comprehensive Plan

The property is designated as “Downtown Mixed Use” on the Land Use Map. The primary use in this designation is a mix of civic, cultural, retail, restaurant, education facilities, medical, hotel/convention, professional offices, financial institutions, medium/high-density housing, government (federal, state, and local) buildings and properties.

6. Recommendation

The project provides an ownership mechanism for the previously approved multi-story commercial building at the intersection of Eighth Street and Main Street. Approval of the condominium plat is subject to compliance with the conditions of approval for DRH11-00240 and DRH1200233. The condominium plat will not alter previous agency comments and requirements. The Planning Team recommends **approval** of the preliminary/final plat of the Eighth and Main Condominiums subject to the following Recommended Conditions of Approval.

7. Recommended Conditions of Approval

Special Conditions and Plat Notes

1. Prior to the signature of the Boise City Engineer, the Final Plat shall be drawn in compliance with the design and conditions of approval for the previously approved Design Review PermitS (DRH11-00240 and DRH12-00233). A note on the face of the Final Plat is required stating, “*The development of this property shall be in compliance with the Boise City Zoning Ordinance as specifically approved by DRH11-00240 and DRH12-00233.*”

Covenant Requirements

2. Covenants, homeowners’ association by-laws, or other similar deed restrictions acceptable to the Boise City Attorney, which provide for the use, control and maintenance of all common areas shall be reviewed and approved by the Boise City Attorney.

Erosion and Sediment Control Requirements

3. Prior to the City Engineer's Certification of the Final Plat and prior to earth disturbing activities, an erosion and sediment control (ESC) permit must be obtained. An ESC plan conforming to the requirements B.C.C. Title 8 Chapter 17, is to be submitted to the Director of Planning and Development Services for review and approval. No grading or earth disturbing activities may start until an approved ESC permit has been issued.

4. An individual who has attended the Boise City Responsible Person (RP) certification class, or has obtained Interim Certification for RP is not identified for this project. A permit will not issue until such time as the name and certification number of the RP has been provided to Boise City. This information can be faxed to 388-4735.

Agency Requirements

5. Compliance with conditions as outlined in a memo from the Boise City Public Works Department relating to drainage, sewer, pressure irrigation, street lights and solid waste collection dated September 5, 2013.
6. Compliance with conditions as outlined in a letter from the Ada County Highway District dated September 9, 2013.
7. Compliance with conditions as outlined in a letter from the Boise City Fire Department, dated September 5, 2013.

General Conditions

8. The developer shall make arrangements to comply with all requirements of the Boise City Fire Department and verify in one of the following ways:
 - A. A letter from the Boise City Fire Department stating that all conditions for water, access, and/or other requirements have been satisfied,

OR

 - B. A non-build agreement has been executed and recorded with a note on the face of the Final Plat identifying the instrument number.

NOTE: “No Parking” signs and curb painting shall be required on streets having a width less than 36-feet, back of curb to back of curb. Contact the Boise City Fire Department for sign placement and spacing. Developer may either construct prior to final platting or post bond in the amount of 110% of the estimated costs with the Boise City Planning and Development Services Department.

9. The name, **8th & Main Condominiums**, is reserved and shall not be changed unless there is a change in ownership, at which time, the new owner(s) shall submit their new name to the Ada County Engineer for review and reservation. Should a change in name occur, applicant shall submit, in writing, from the Ada County Surveyor, the new name to the Department of Planning and Development Services and re-approval by the Council of the "revised" Final Plat shall be required. Developer and/or owner shall submit all items including fees, as required by the Planning and Development Services Department, prior to scheduling the "revised" Final Plat for hearing.

10. Correct street names as approved by the Ada County Street Name Committee shall be placed on the plat (B.C.C. 9-06-05.M.).
11. A letter of acceptance for water service from the utility providing same is required (B.C.C. 11-09-04.3.).
12. Developer shall provide utility easements as required by the public utility providing service (B.C.C. 11-09-03.6.).
13. A letter from the appropriate school district is required stating, "The Developer has made arrangements to comply with all requirements of the Independent School District of Boise City #1."
14. Developer shall provide a letter from the United States Postal Service stating, "The Developer and/or Owner has received approval for location of mailboxes by the United States Postal Service."

Contact: Dan Frasier, Postmaster
770 S. 13th St.
Boise, ID 83708-0100
Phone No. (208) 433-4341
FAX No. (208) 433-4400

15. Prior to submitting the Final Plat for recording, the following endorsements or certifications must be executed: Signatures of owners or dedicators, Certificate of the Surveyor, Certificate of the Ada County Surveyor, Certificate of the Central District Health Department, Certificate of the Boise City Engineer, Certificate of the Boise City Clerk, signatures of the Commissioners of the Ada County Highway District and the Ada County Treasurer (I.C. Title 50, Chapter 13).
16. Developer shall comply with B.C.C. 11-03-04.4. which specifies the limitation on time for filing and obtaining certification. Certification by the Boise City Engineer shall be made within two years from date of approval of the Final Plat by the Boise City Council.
 - A. The developer may submit a request for a time extension, including the appropriate fee, to the Boise City Planning and Development Services Department for processing. Boise City Council may grant time extensions for a period not to exceed one year provided the request is filed, in writing, at least twenty working days prior to the expiration of the first two year period, or expiration date established thereafter.
 - B. If a time extension is granted, the Boise City Council reserves the right to modify and/or add condition(s) to the original preliminary or Final Plat to conform with adopted policies and/or ordinance changes.

- C. The Final Plat shall be recorded with the Ada County Recorder within one year from the date of the Boise City Engineer's signature. If the Final Plat is not recorded within the one-year time frame it shall be deemed null and void.
17. The **8th & Main Condominiums** are approved for 22 units and one common area.

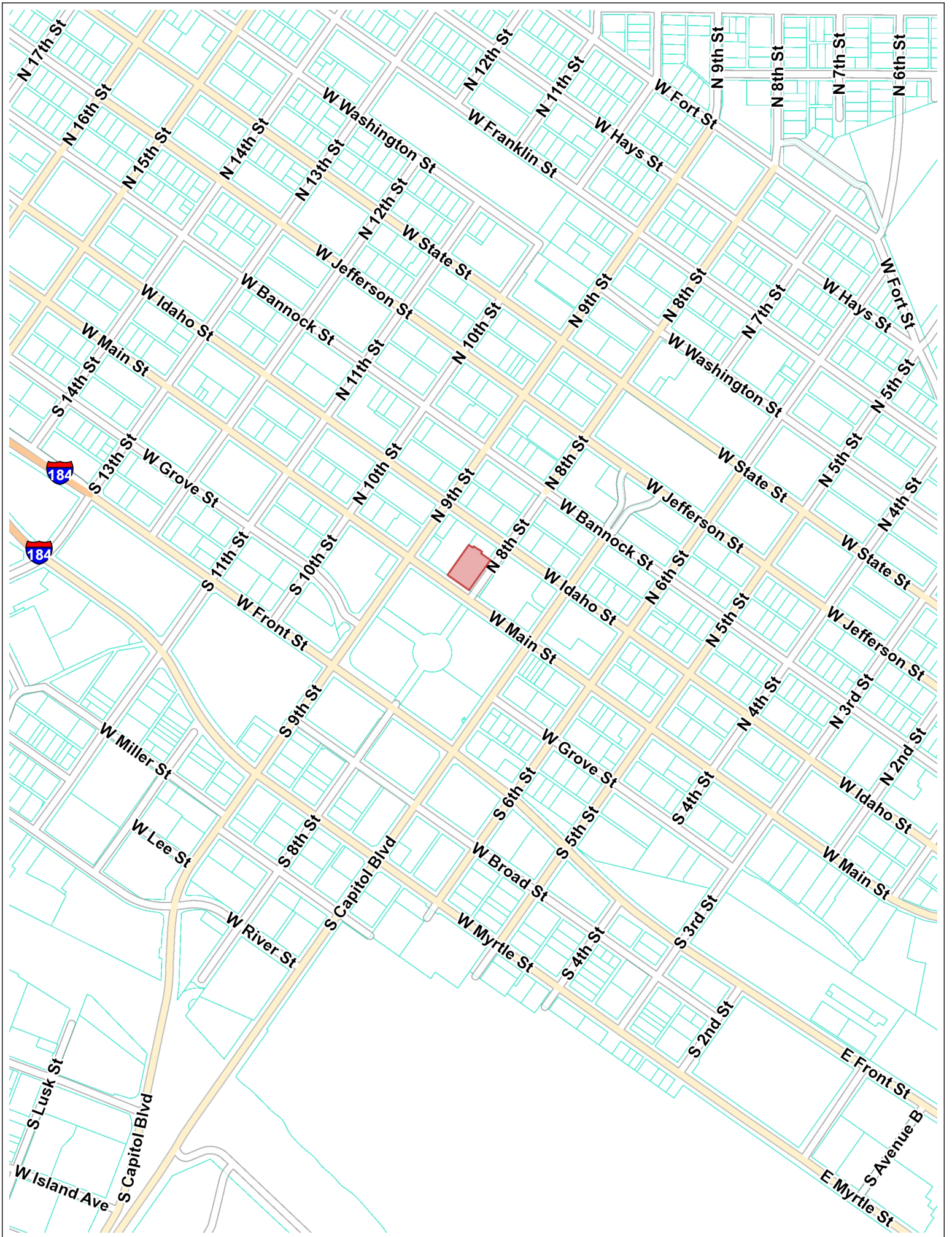

PLAT SHOWING EIGHTH AND MAIN CONDOMINIUMS

SECTION 10, T3N, R2E, BOISE MERIDIAN
ADA COUNTY, IDAHO

LEGAL DESCRIPTION

A PARCEL OF LAND BEING ALL OF LOTS 5 AND 6, PORTIONS OF LOTS 4, 10, 11 AND 12 AND PORTIONS OF THE VACATED 8TH STREET AND ALLEY OF BLOCK 2 OF THE BOISE CITY ORIGINAL TOWNSITE, ACCORDING TO THE OFFICIAL PLAT THEREOF, FILED IN BOOK 1 OF PLATS AT PAGE 1, RECORDS OF ADA COUNTY, IDAHO, LYING IN THE NORTHEAST QUARTER OF SECTION 10, TOWNSHIP 3 NORTH, RANGE 2 EAST, BOISE MERIDIAN, ADA COUNTY, IDAHO; AND MORE PARTICULARLY DESCRIBED AS FOLLOWS:

COMMENCING AT AN ALUMINUM CAP MARKING THE CENTERLINE INTERSECTION OF WEST MAIN STREET AND NORTH 8TH STREET; THENCE NORTH 54°48'37" WEST ALONG SAID CENTERLINE OF WEST MAIN STREET, A DISTANCE OF 30.00 FEET; THENCE NORTH 35°13'52" EAST 40.00 FEET TO THE REAL POINT OF BEGINNING; THENCE NORTH 54°48'37" WEST ALONG THE EXTENDED SOUTHWESTERLY BOUNDARY, AND THE SOUTHWESTERLY BOUNDARY OF SAID LOTS 4, 5 AND 6 A DISTANCE OF 135.80 FEET; THENCE NORTH 35° 12'48" EAST A DISTANCE OF 189.81 FEET; THENCE SOUTH 55°07'01" EAST A DISTANCE OF 25.14 FEET; THENCE NORTH 34°52'59" EAST A DISTANCE OF 8.55 FEET; THENCE SOUTH 54°59'32" EAST A DISTANCE OF 30.91 FEET; THENCE NORTH 34°52'59" EAST A DISTANCE OF 1.50 FEET; THENCE SOUTH 54°59'32" EAST A DISTANCE OF 20.55 FEET; THENCE SOUTH 35°12'05" WEST A DISTANCE OF 10.43 FEET; THENCE SOUTH 54°47'55" EAST A DISTANCE OF 24.00 FEET; THENCE SOUTH 54°47'55" EAST A DISTANCE OF 35.31 FEET; THENCE SOUTH 35°13'52" WEST ALONG A LINE 30 FEET NORTHWESTERLY OF THE CENTERLINE OF NORTH 8TH STREET, A DISTANCE OF 189.72 FEET TO THE REAL POINT OF BEGINNING.

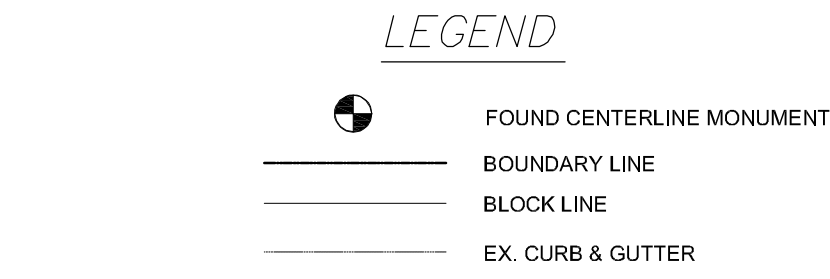
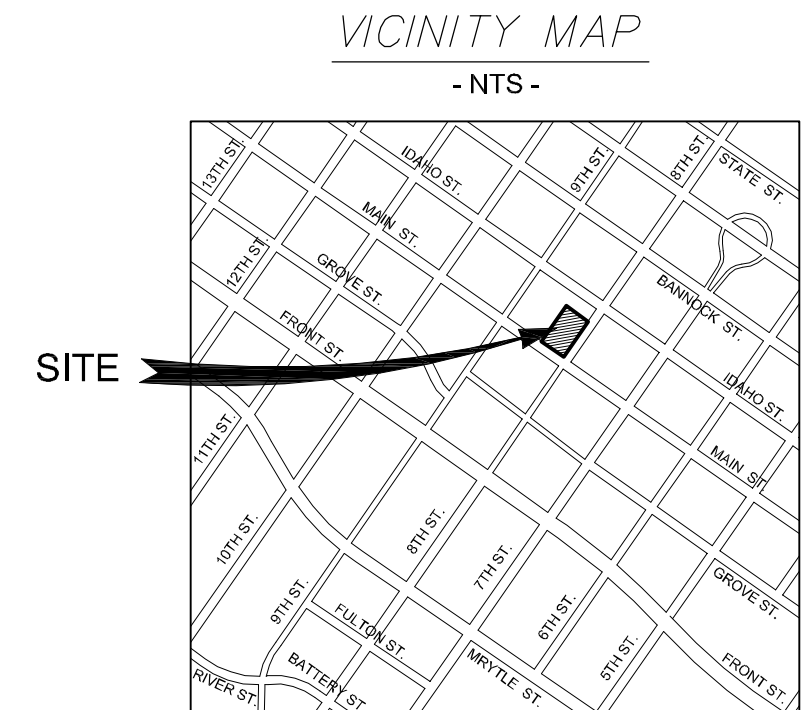
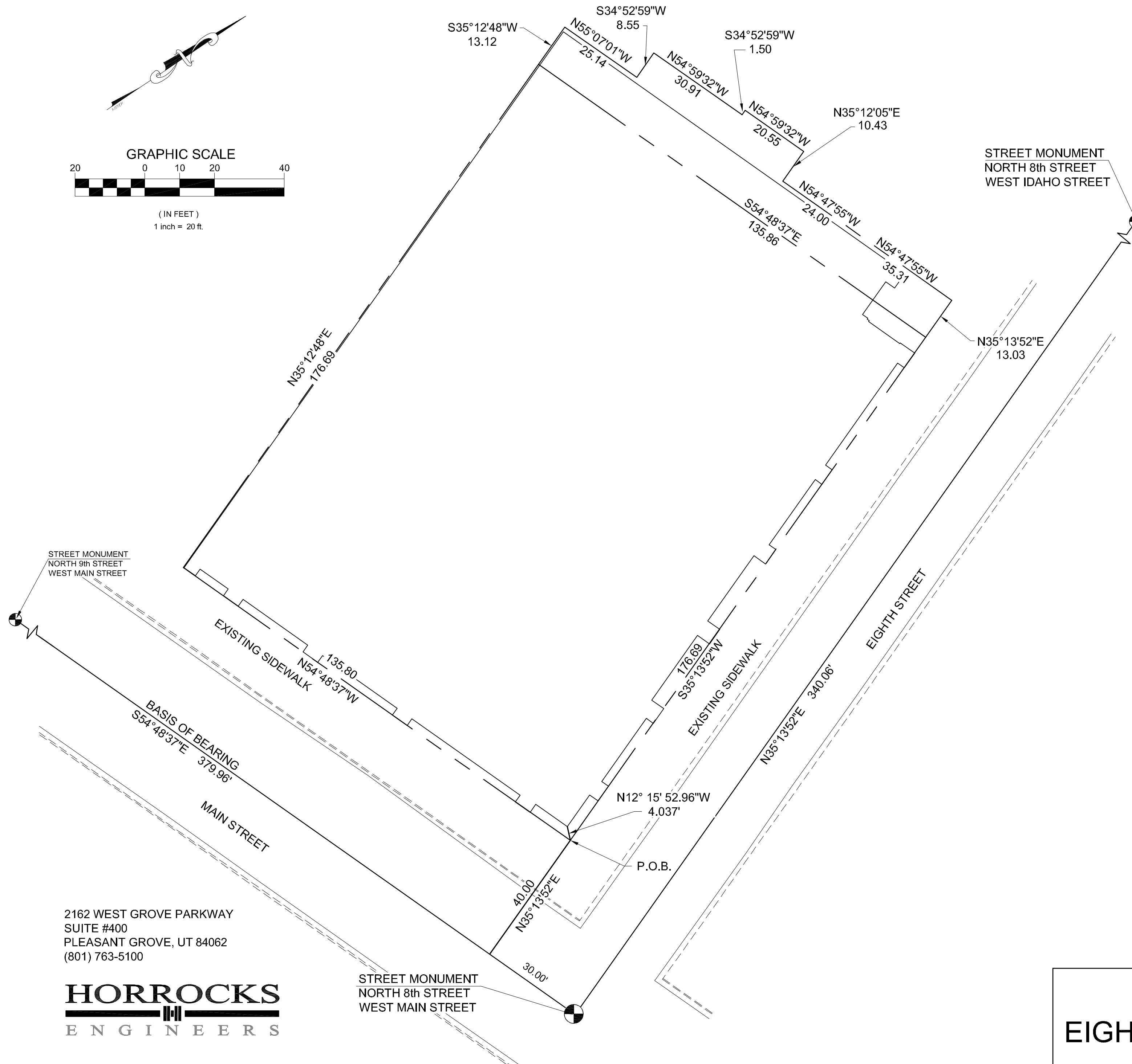
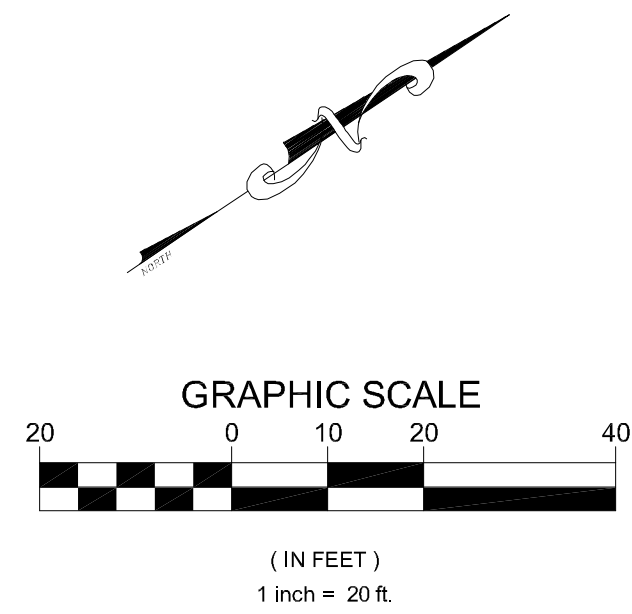

2162 WEST GROVE PARKWAY
SUITE #400
PLEASANT GROVE, UT 84062
(801) 763-5100



SHEET 1 OF 11

PLAT OF
EIGHTH AND MAIN CONDOMINIUMS

C:\2011\SL-826-1108 Eighth and Main\Design\Right_of_Way\Condo Plat\PLAT\CONDO PLAT 7-31-13.dwg

0: \2011\SI--826--1108 Eighth and Main\Design\Right_of_Way\Condo Plat\PLAT CONDO PLAT 7-31-13.dwg

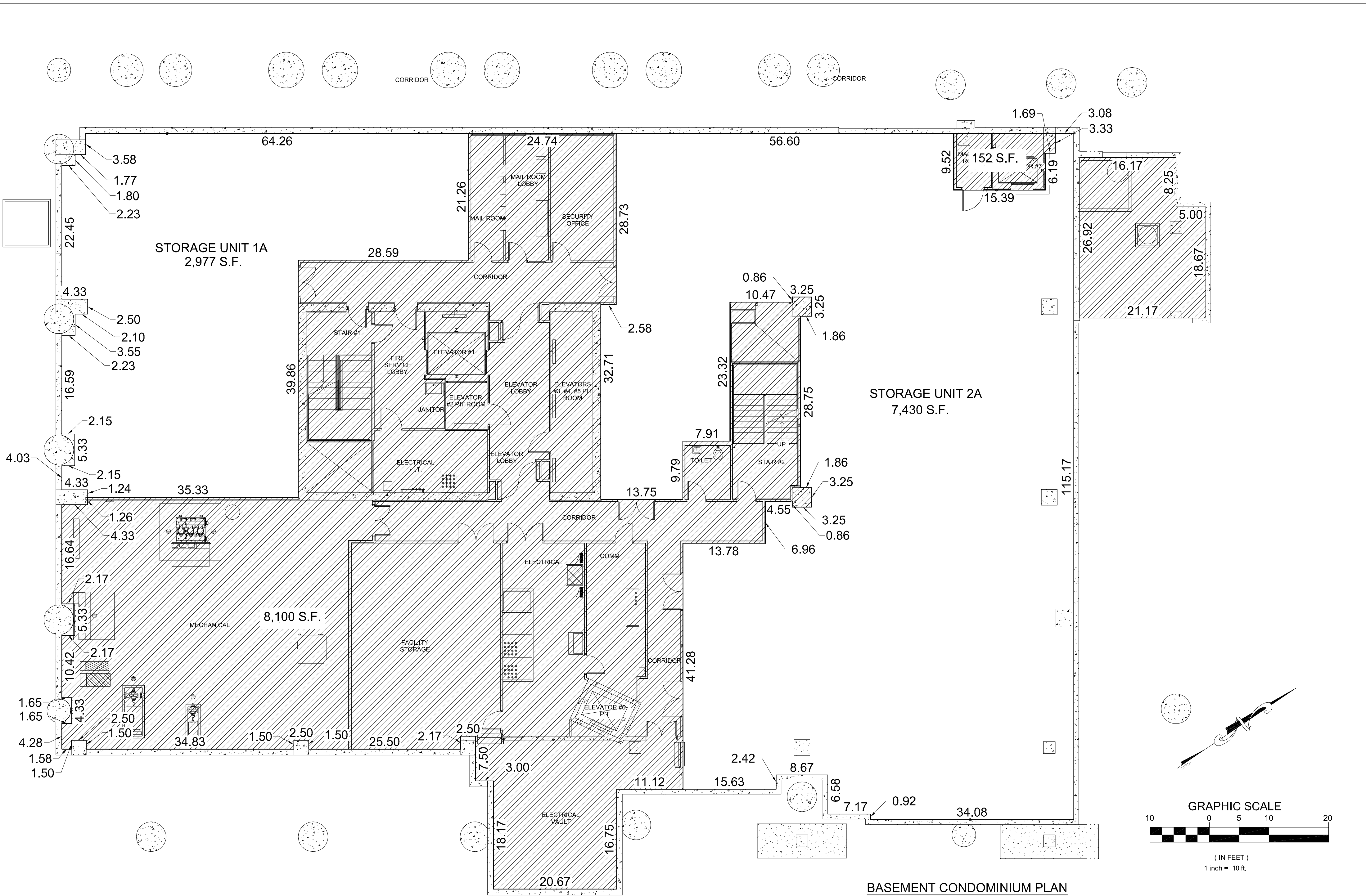

LEGEND

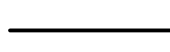
-  COMMON AREA
-  UNIT BOUNDARY LINE

HORROCKS
ENGINEERS

2162 WEST GROVE PARKWAY
SUITE #400
PLEASANT GROVE, UT 84062
(801) 763-5100

BASEMENT CONDOMINIUM PLAN

SHEET 2 OF 11

PLAT OF
EIGHTH AND MAIN CONDOMINIUMS

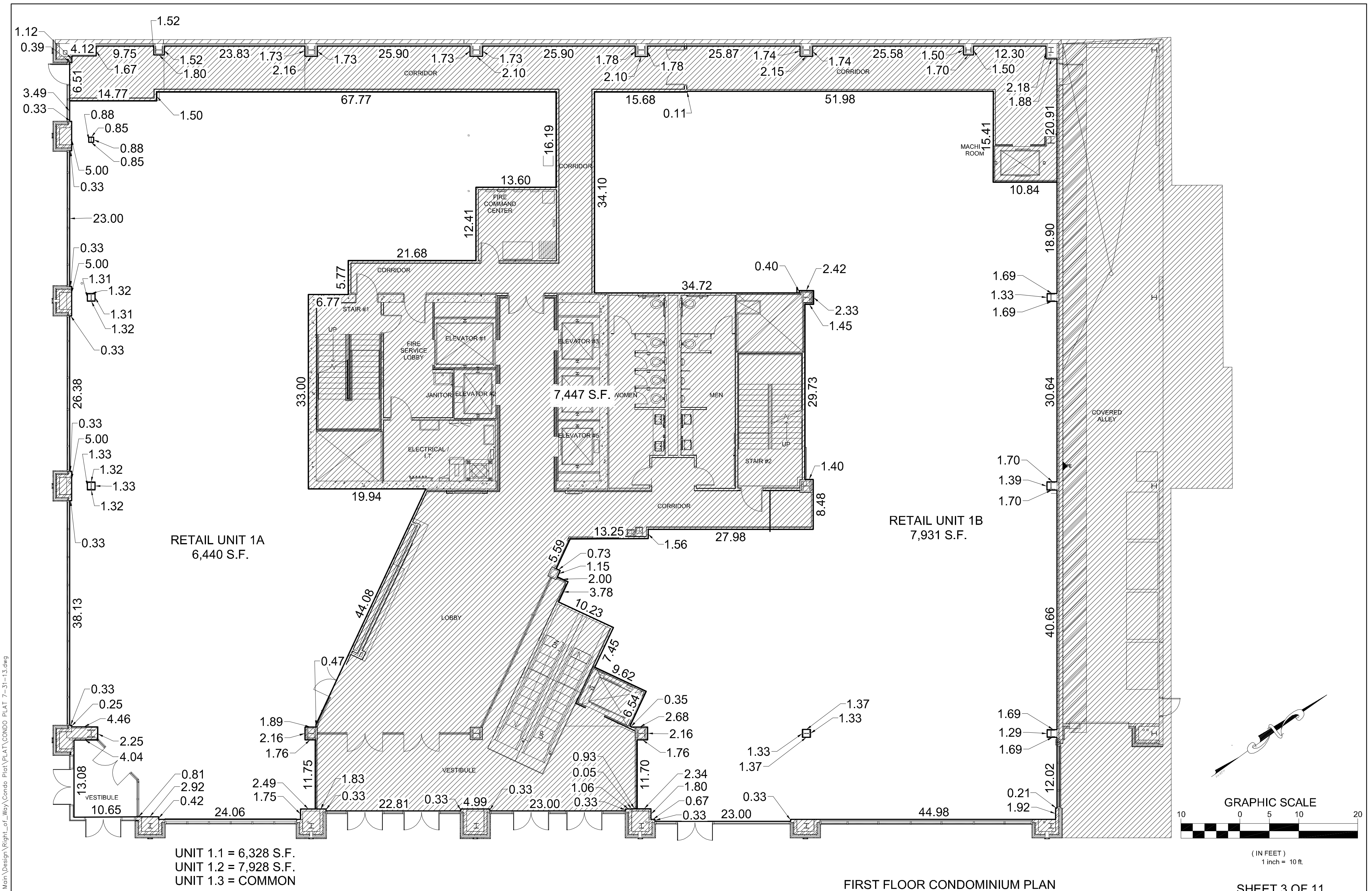

RETAIL UNIT 1A
6,440 S.F.

RETAIL UNIT 1B
7,931 S.F.

UNIT 1.1 = 6,328 S.F.
UNIT 1.2 = 7,928 S.F.
UNIT 1.3 = COMMON

FIRST FLOOR CONDOMINIUM PLAN

LEGEND

-  COMMON AREA
-  UNIT BOUNDARY LINE

HORROCKS
ENGINEERS

2162 WEST GROVE PARKWAY
SUITE #400
PLEASANT GROVE, UT 84062
(801) 763-5100

PLAT OF
EIGHTH AND MAIN CONDOMINIUMS

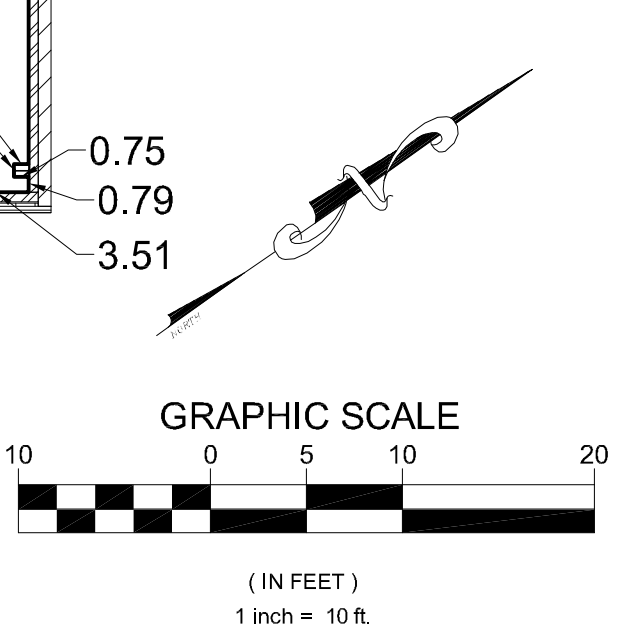
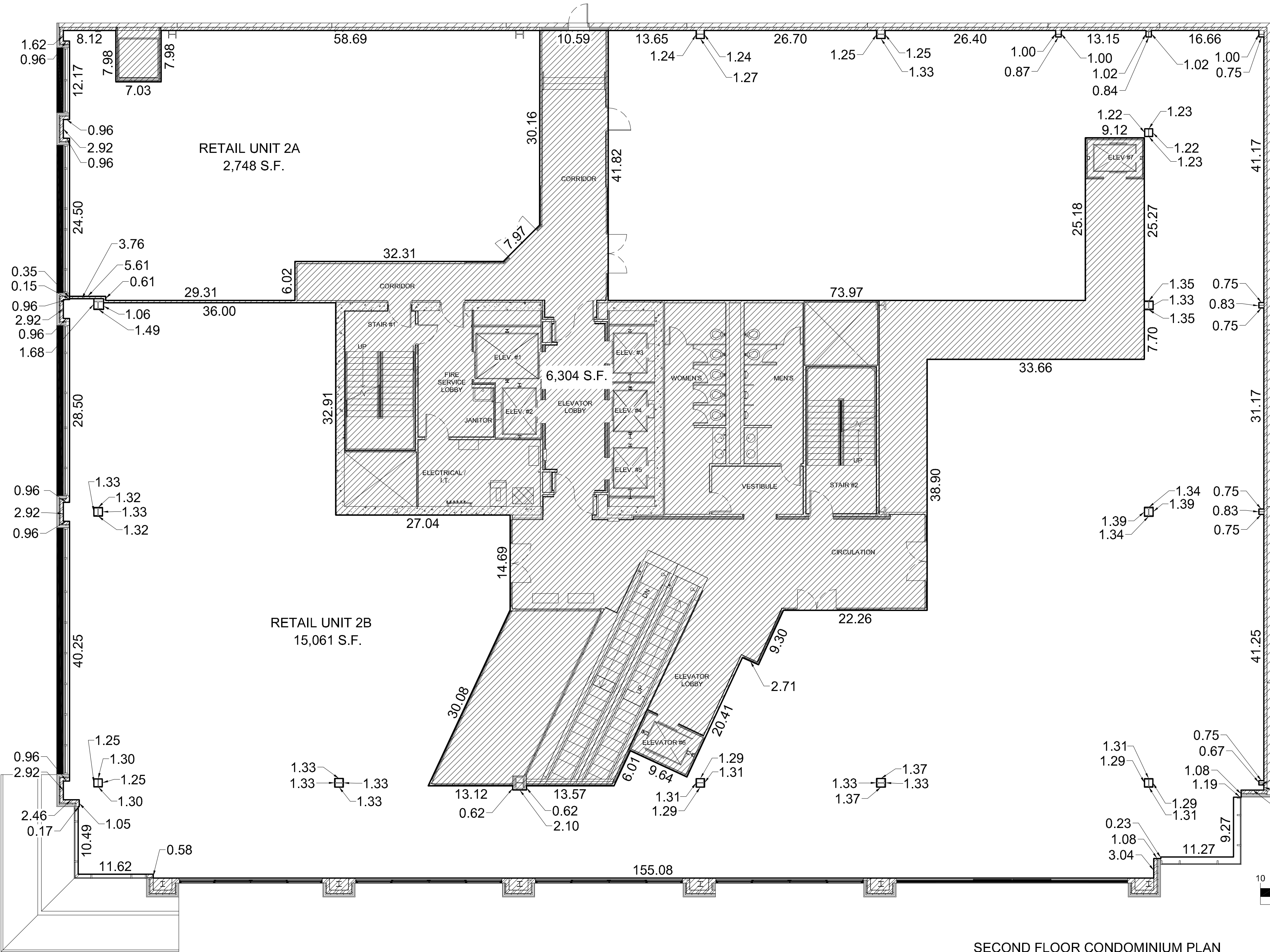

O:\2011\SI--826-1108 Eighth and Main\Design\Right_of_Way\Condo Plat\PLAT\CONDO PLAT 7-31-13.dwg

Q:\2011\SI--826-1108 Eighth and Main\Design\Right_of_Way\Condo Plat\COND PLAT 7-31-13.dwg



SECOND FLOOR CONDOMINIUM PLAN

LEGEND

-  COMMON AREA
-  UNIT BOUNDARY LINE

HORROCKS
ENGINEERS

2162 WEST GROVE PARKWAY
SUITE #400
PLEASANT GROVE, UT 84062
(801) 763-5100

PLANTOOP

EIGHTH AND MAIN CONDOMINIUMS

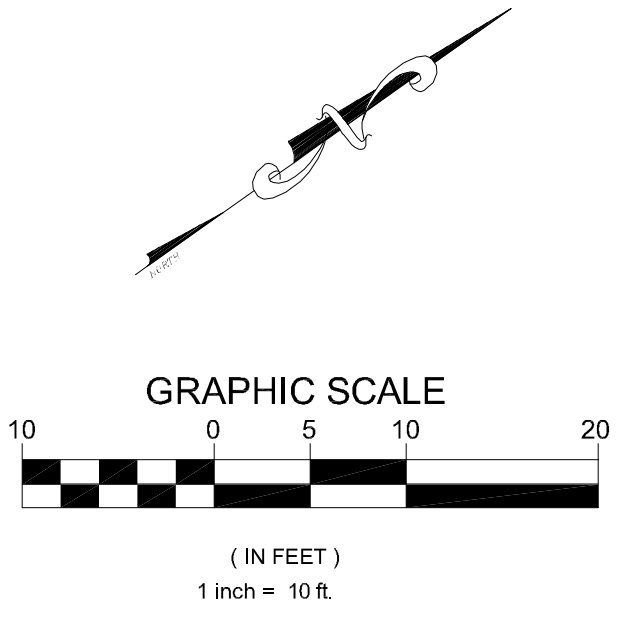
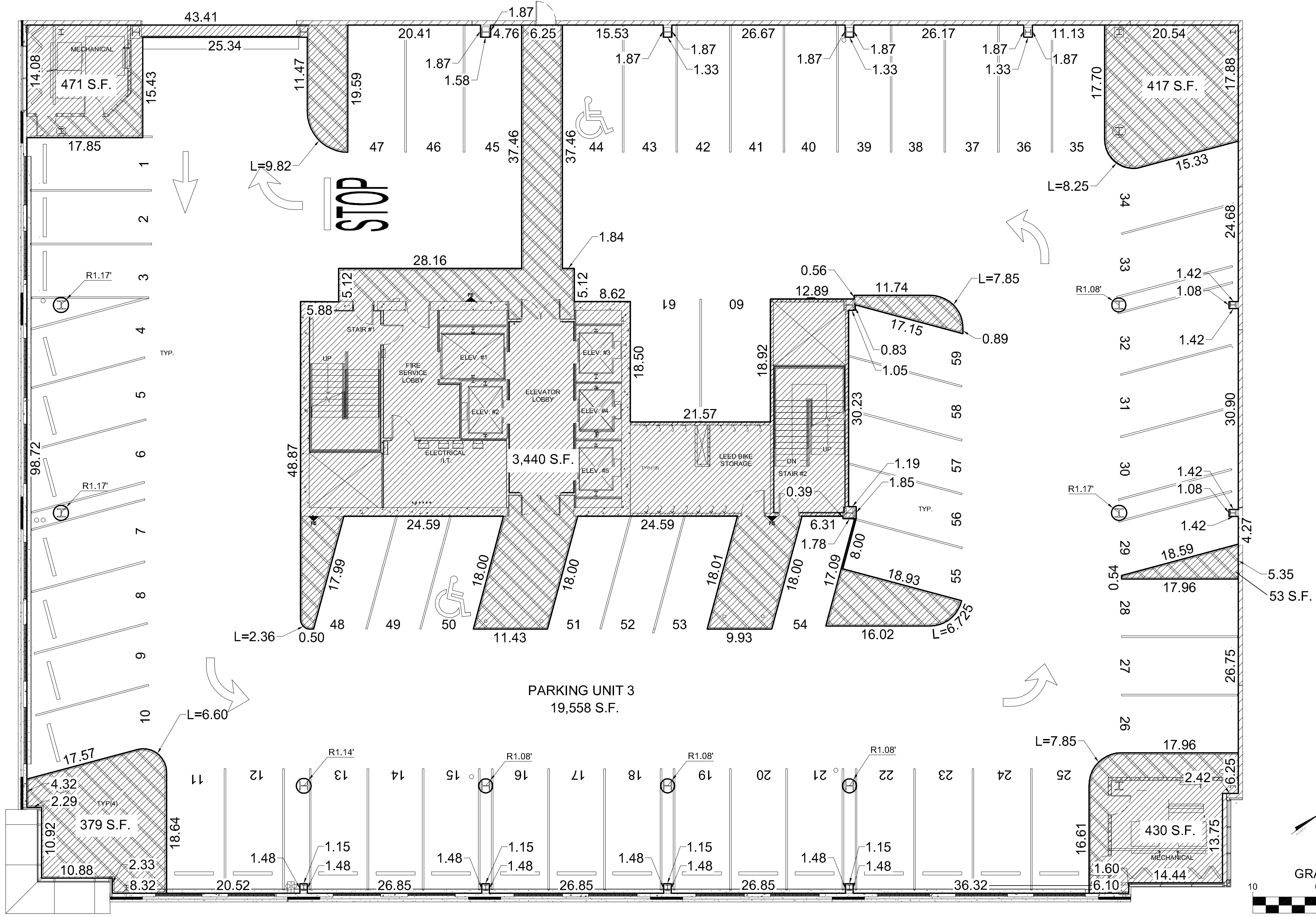

LEGEND

- COMMON AREA
- UNIT BOUNDARY LINE

HORROCKS
ENGINEERS

2162 WEST GROVE PARKWAY
SUITE #400
PLEASANT GROVE, UT 84062
(801) 763-5100

THIRD FLOOR CONDOMINIUM PLAN

SHEET 5 OF 11

PLAT OF
EIGHTH AND MAIN CONDOMINIUMS

O:\2011\SI--826-1108 Eighth and Main\Design\Right_of_Way\Condo Plat\PLAT CONDO PLAT 7-31-13.dwg

C:\2011\SI--826--1108 Eighth and Main\Design\Right_of_Way\Condo Plat\PLAT\CONDOPLAT 7-31-13.dwg

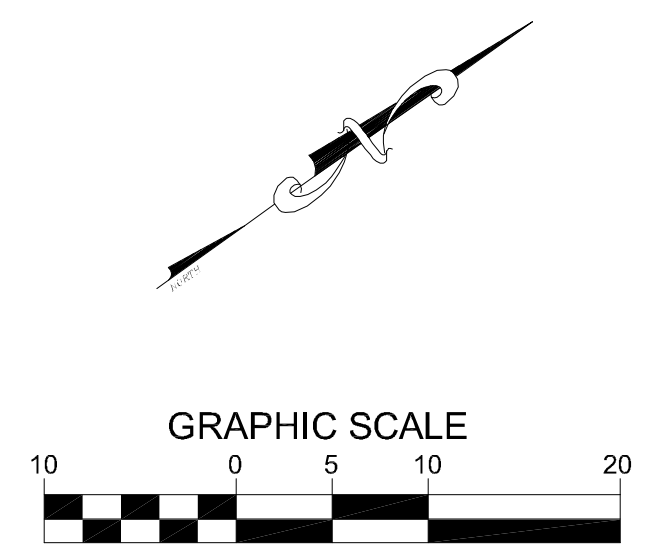
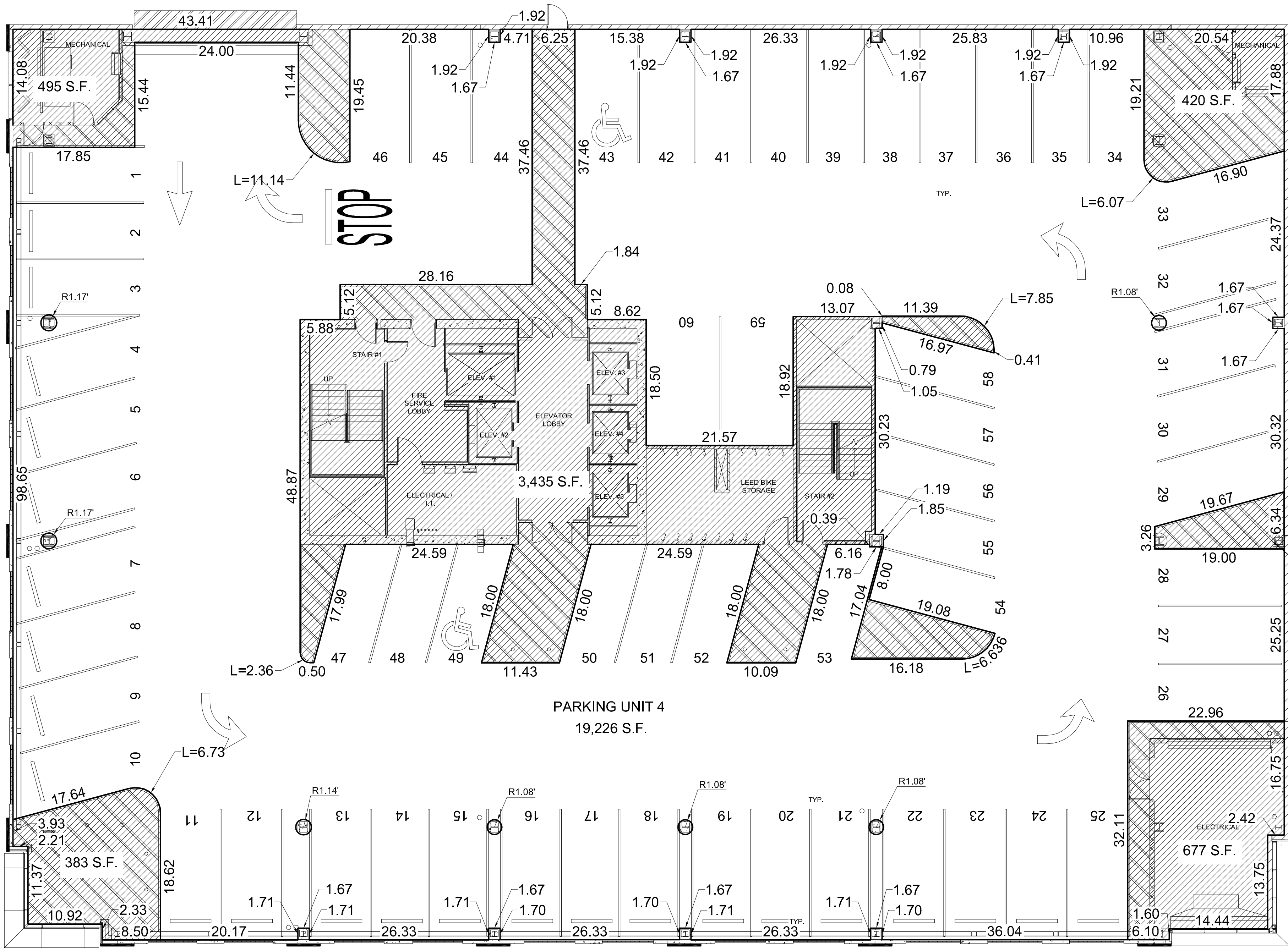



GRAPHIC SCALE
(IN FEET)
1 inch = 10 ft.

FOURTH FLOOR CONDOMINIUM PLAN

SHEET 6 OF 11

LEGEND

-  COMMON AREA
-  UNIT BOUNDARY LINE

HORROCKS
ENGINEERS

2162 WEST GROVE PARKWAY
SUITE #400
PLEASANT GROVE, UT 84062
(801) 763-5100

PLAT OF
EIGHTH AND MAIN CONDOMINIUMS

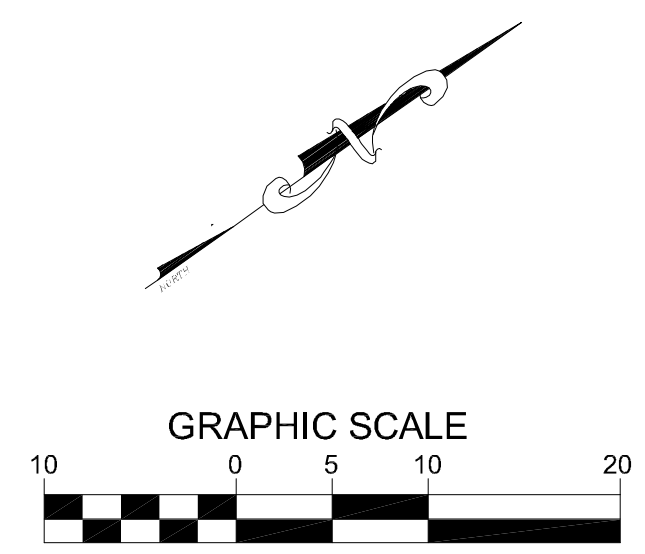
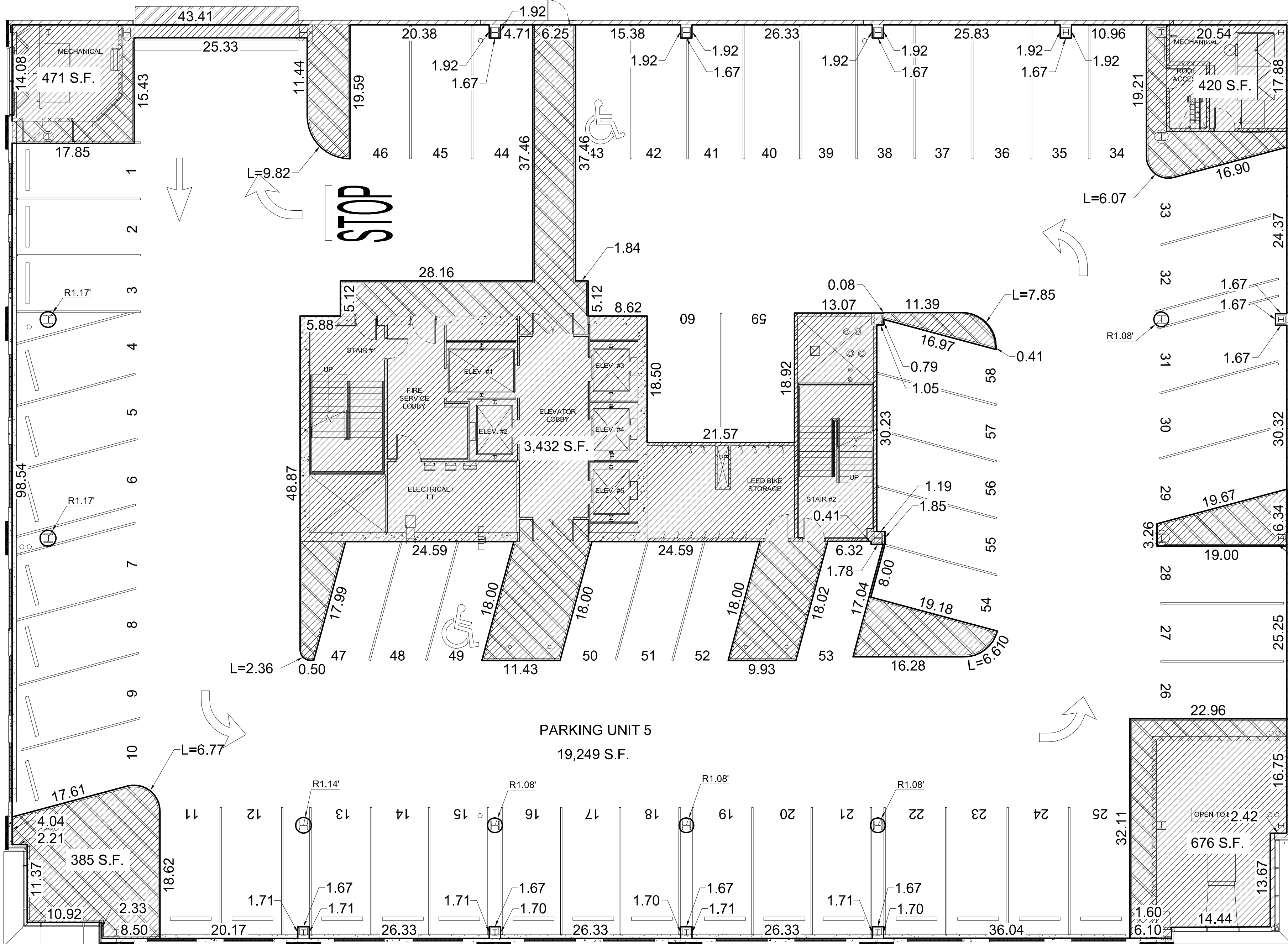

LEGEND

- COMMON AREA
- UNIT BOUNDARY LINE

HORROCKS
ENGINEERS

2162 WEST GROVE PARKWAY
SUITE #400
PLEASANT GROVE, UT 84062
(801) 763-5100

FIFTH FLOOR CONDOMINIUM PLAN

SHEET 7 OF 11

PLAT OF
EIGHTH AND MAIN CONDOMINIUMS

O:\2011\SI--826-1108 Eighth and Main\Design\Right_of_Way\Condo Plat\PLAT\CONDO PLAT 7-31-13.dwg

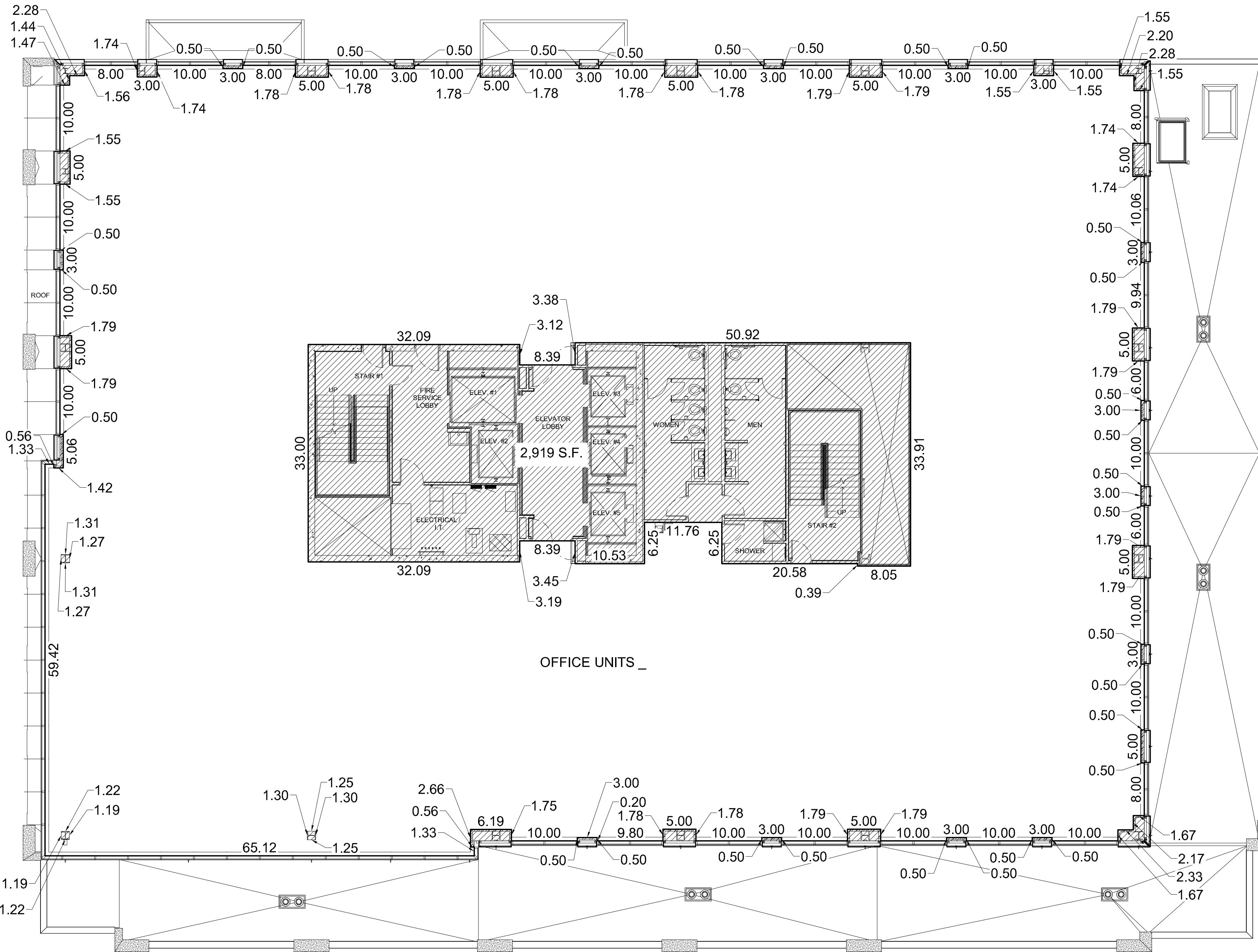

- UNITS 6 = 16,540 S.F.
- UNITS 7 = 16,540 S.F.
- UNITS 8 = 16,540 S.F.
- UNITS 9 = 16,540 S.F.
- UNITS 10 = 16,540 S.F.
- UNITS 11 = 16,540 S.F.
- UNITS 12 = 16,540 S.F.
- UNITS 13 = 16,540 S.F.
- UNITS 14 = 16,540 S.F.
- UNITS 15 = 16,540 S.F.
- UNITS 16 = 16,540 S.F.

CONDOMINIUM PLAN FOR UNITS 6 THROUGH 16

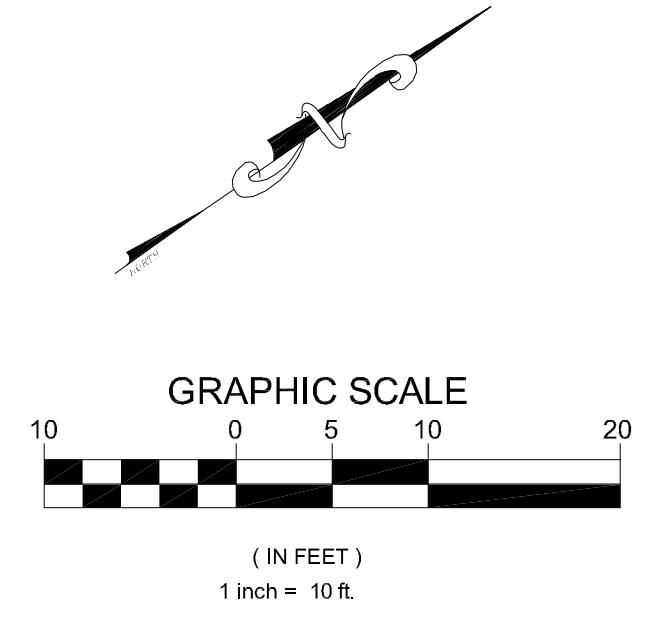

LEGEND

- COMMON AREA
- UNIT BOUNDARY LINE

HORROCKS
ENGINEERS

2162 WEST GROVE PARKWAY
SUITE #400
PLEASANT GROVE, UT 84062
(801) 763-5100

PLAT OF
EIGHTH AND MAIN CONDOMINIUMS

O:\2011\SI--826-1108 Eighth and Main\Design\Right_of_Way\Condo Plat\PLAT\CONDO PLAT 7-31-13.dwg

O:\2011\SI--826-1108 Eighth and Main\Design\Right_of_Way\Condo Plat\PLAT\CONDO PLAT 7-31-13.dwg

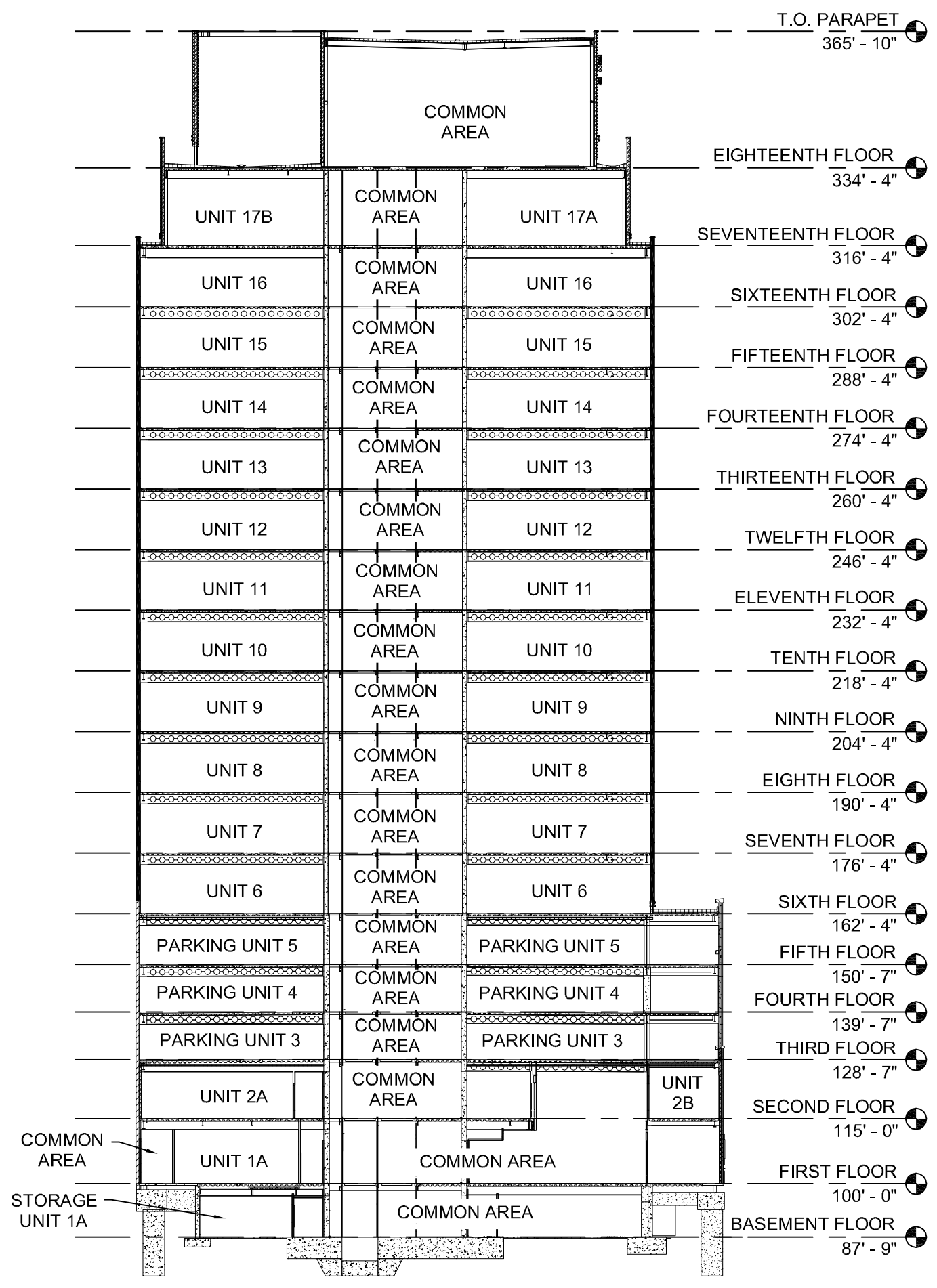

BUILDING SECTION EAST - WEST

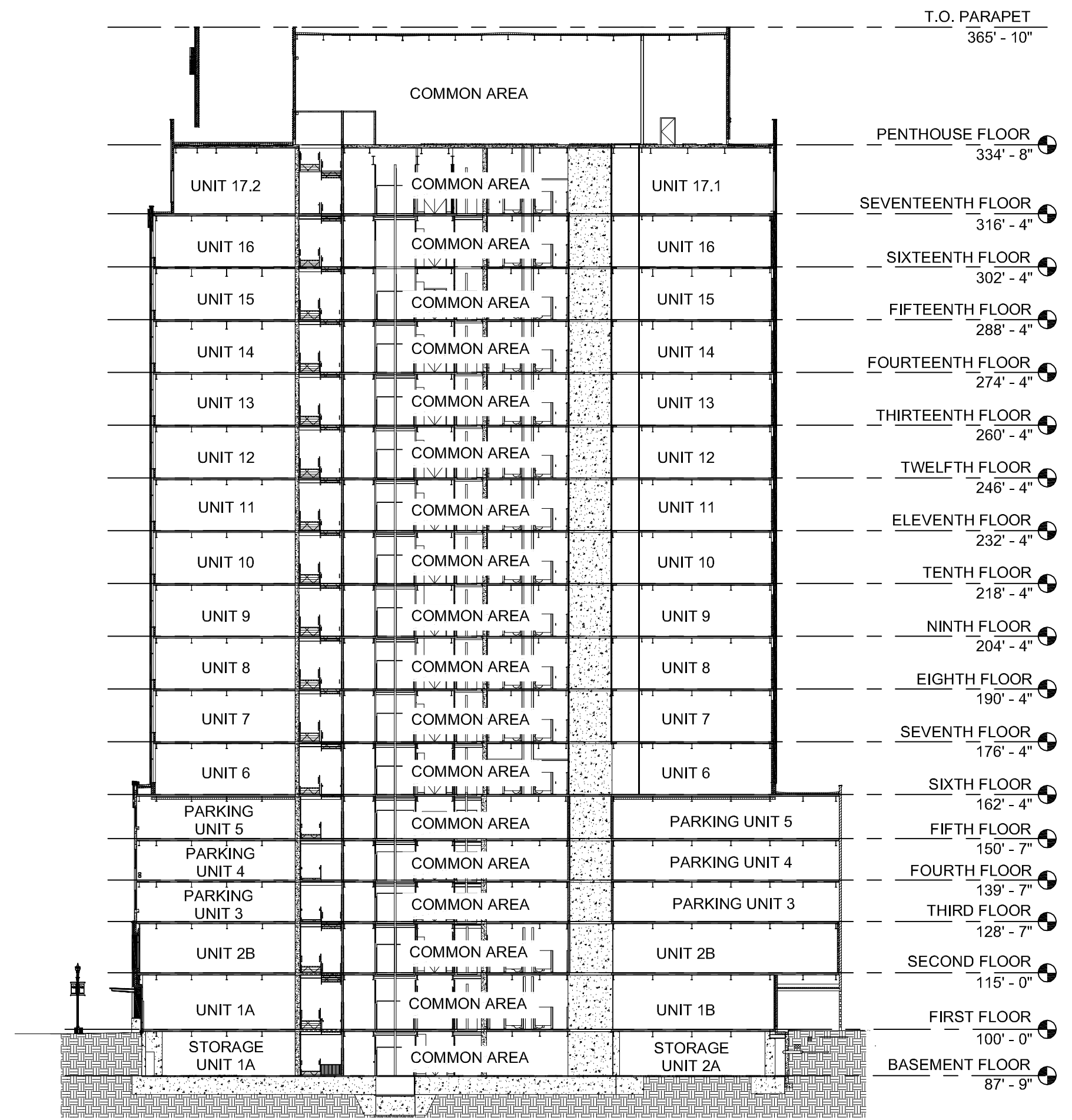

BUILDING SECTION NORTH - SOUTH

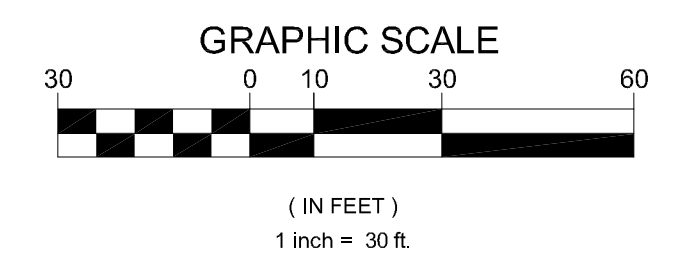
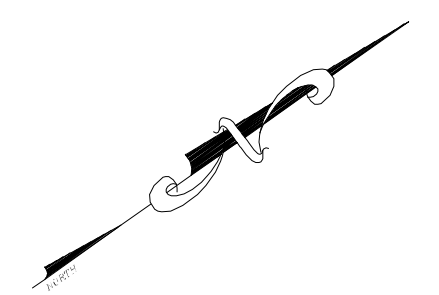

SHEET 10 OF 11

LEGEND

COMMON AREA

UNIT BOUNDARY LINE

HORROCKS
ENGINEERS

2162 WEST GROVE PARKWAY
SUITE #400
PLEASANT GROVE, UT 84062
(801) 763-5100

PLAT OF
EIGHTH AND MAIN CONDOMINIUMS



W Idaho St
W Idaho St

N 8th St

N 8th St

W Main St

Table of Contents

[Standard Grading and Drainage Conditions](#)
[Standard Irrigation Conditions](#)
[Standard Sewer Conditions](#)

[Standard Street Light Conditions](#)
[Standard Hillside Conditions](#)
[Misc. Engineering Conditions](#)
[Misc. Solid Waste Conditions](#)

PW SUBDIVISION COMMENTS

REV 12/03/12

Date Due: 09/05/2013
Transmittal Date: 08/29/2013
Tentative Hearing Date: 10/07/2013
Subject: 8th and Main; SUB13-00040
Plat: Final

Engineer/Surveyor/Planner: Horrocks Engineers
Phone: 801-763-5100

When finished with comments, please type initials below.

To:					Initials
<input checked="" type="checkbox"/>	Public Works	Rob Bousfield	Drainage, Hillside, Misc. Engineering	384-3914	RJB
<input checked="" type="checkbox"/>	Public Works	Mike Hedge	Municipal Lighting	388-4719	MH
<input checked="" type="checkbox"/>	Public Works	Mike Sheppard	Sewer	384-3920	MS
<input checked="" type="checkbox"/>	Public Works	Mike Sheppard	Pressure Irrigation	384-3920	MS
<input checked="" type="checkbox"/>	Public Works	Peter McCullough	Solid Waste	384-3906	PJM

B.C.C 9-20-05.C.4, *Procedures; Preliminary Plat* of the Boise City Subdivision Ordinance provides that if no written recommendation from any agency listed herein is received within five (5) days after such notification, the approval of the Final Plat by such agency will be considered granted.

If you would like access to better resolution drawings (i.e., site and landscape drawings) please refer to: <http://pdsonline.cityofboise.org/pdsonline/CaseSearch.aspx> by using the case number.

1. STANDARD GRADING AND DRAINAGE CONDITIONS

REV 9/12/07

Special Conditions: Comply with approved drainage permit.

2. STANDARD IRRIGATION CONDITIONS

REV 12/6/07

- a. Comply with B.C.C. 11-09-04.6. concerning pressure irrigation requirements prior to signing of the final plat by the Boise City Engineer.
 - i) The owner, person, firm or corporation filing the subdivision plat shall provide written documentation that a valid waiver of the requirement to provide a pressure irrigation system and that Idaho Code 31-3805(1)(a) regarding transfer of water rights, has been complied with.

**Special Conditions:
Condominium Plat**

3. STANDARD SEWER CONDITIONS

REV 12/03/12

City Subdivision Conditions

- a. Wetline sewers are required (B.C.C. 11-09-04.4., *Required Improvements; Sanitary Sewers*).

Developer and/or owner shall comply with all provisions of the Boise City “Sewer Tap” Ordinances.

- i) Developer and/or owner may either construct prior to final platting or post bond/agreement in the amount of 110% of the estimated costs. Please contact the Public Works Department for specifications and inspections during construction.

NOTE: All bonding shall conform to B.C.C. 11-09-04.2., *Filing of Plans and Bonding Surety*, which specifies that the improvements to be made shall be done in a time period not to exceed one year from the date of approval of the final plat.

- b. Provide recorded subdivision/condominium covenants regarding ownership and maintenance of the common private sewer collection system.

4. STANDARD STREET LIGHT CONDITIONS

REV 9/12/07

City Subdivision Conditions

- a. Developer shall delineate on the face of the final plat a Boise City street light easement, acceptable to the Boise City Department of Public Works, for the purpose of installing and maintaining city-owned street light fixtures, conduit, and wiring lying outside the dedicated public right-of-way (B.C.C. 11-09-03.6.).
- b. The developer shall be required to install, at their expense, street lights in accordance with Boise City Public Works specifications and standards at locations designated by the Public Works Department (B.C.C. 11-09-04.9.). Plans shall be reviewed and approved by the Boise City Public Works Department prior to commencement of construction or bonding.
- c. **Fees:** Developer shall pay the current street light inspection and plan review fees on the proposed subdivision (B.C.C. 11-03-03.3.B.).
- d. The street lights shall be installed and accepted by the Boise City Public Works Department at the following locations. Unless otherwise noted, street lights shall be installed at a 25-foot minimum mounting height, 50 watt class LED fixture (see Attachment A, Boise Standard Revisions for a list of approved fixtures)
 - i) Light Locations:
 - N/A
- e. If approval for bonding is granted by the Boise City Public Works Department, developer may bond in the amount of 110% of the estimated street light costs. Street lights shall be installed within 90 days of the issuance of the first building permit in the development, if building permits are obtained prior to completion of street light improvements.

Special Conditions: Comply with existing street light conditions in BLD13-01991.

5. STANDARD HILLSIDE CONDITIONS

REV 9/12/07

N/A

6. MISC. ENGINEERING CONDITIONS

REV 9/12/07

N/A

7. MISC. SOLID WASTE CONDITIONS

REV 3/11/11

N/A

[Back to top](#)

**Finalized/Sent:
LR 09/06/13**



Rebecca W. Arnold, President
Sara M. Baker, Vice President
John S. Franden, Commissioner
Carol A. McKee, Commissioner
Mitchell A. Jaurena, Commissioner

Date: September 9, 2013

To: Geoffrey Wardle, via e-mail
Eighth and Main, LLC
101 S. Capitol Blvd.
Boise, ID 83702

Subject: SUB13-00040
800 W. Main St.
Condominium plat for the Eighth and Main Condominiums.

This is a staff level approval of a preliminary plat for the Eighth and Main Condominiums. On December 7, 2011 the Ada County Highway District reviewed and approved a design review application (DRH11-00240) proposed to contain a high rise tower in downtown Boise.

On August 28, 20013 the District received a condominium plat application that proposed to condominimize the previously approved development. The District does not have any additional requirements at this time.

The applicant will be required to pay all applicable platting and review fees prior to final approval.

The applicant shall be required to meet all of the ACHD Standard Conditions of Approval as well as all ACHD Policies and requirements that may apply as noted below.

If you have any questions, please feel free to contact me at (208) 387-6335.

Sincerely,

Austin Miller
Planning Review Intern
Development Services

CC: Project file,
City of Boise, via e-mail
Rob Sunderlage, via e-mail



Rebecca W. Arnold, President
John S. Franden, Vice President
Carol A. McKee, Commissioner
Sara M. Baker, Commissioner
David L. Case, Commissioner

December 7, 2011

To: Eighth and Main, LLC – Tommy Ahlquist
3277 E. Louise Drive, # 375
Meridian, ID 83642

Subject: DRH11-00240/Boise Tower

On December 7, 2011 the Ada County Highway District Commission acted on your application for the above referenced project. The attached report lists site-specific requirements, conditions of approval and street improvements, which are required.

If you have any questions, please feel free to contact me at (208) 387-6178.

Sincerely,

Mindy Wallace
Planning Review Supervisor
Development Services
Ada County Highway District

CC: Project file
City of Boise
Horrocks Engineers – Rob Sunderlage
Babcock Design Group – T.J. Winger



Project/File: DRH11-00240

This application is a design-review application to construct a 15-20 story high rise building in downtown Boise. The site is located at 800 W. Main Street in Boise, Idaho.

Lead Agency: City of Boise

Site address: 800 W. Main Street

Commission Hearing: December 7, 2011
consent agenda

Commission Approval: December 7, 2011

Applicant: Eighth & Main LLC - Tommy Ahlquist
3277 Louise Drive, Suite 375
Meridian, ID 83642

Representative: Babcock Design Group - TJ Winger
52 Exchange Place
Salt Lake City, UT 84111

Staff Contact: Mindy Wallace
Phone: 387-6178
E-mail: mwallace@achdidaho.org



A. Findings of Fact

1. **Description of Application:** The applicant is requesting design-review approval to construct a 15-20 story high rise tower in downtown Boise. The first two levels are to be retail-use, levels 3-5 are for parking and levels 6-15 (possibly 6-20) are to be used as office space. The total retail and office space is proposed to be 352,079 square feet. The parking garage is to be 76,149 square feet with 174 parking stalls.

2. **Description of Adjacent Surrounding Area:**

Direction	Land Use	Zoning
North	Central Business	C-5
South	Central Business	C-5
East	Central Business	C-5
West	Central Business	C-5

3. **Site History:** ACHD previously reviewed this site as DRH98-071 in May of 1998.

4. **Impact Fees:** There will be an impact fee that is assessed and due prior to issuance of any building permits. The assessed impact fee will be based on the impact fee ordinance that is in effect at that time.

5. Capital Improvements Plan (CIP)/Five Year Work Plan (FYWP):

There are currently no roadways, bridges or intersections in the general vicinity of the project that are currently in the Five Year Work Program or the District's Capital Improvement Plan (CIP).

B. Traffic Findings for Consideration

1. Trip Generation (if TIS required): The trip generation for this site is unknown at this time. The applicant has not yet submitted the required traffic impact study for this project (see number 2 below). Staff estimates this site will generate 5,000 to 6,000 additional vehicle trips per day with 500 to 600 trips in the PM peak hour.

2. Traffic Impact Study

Traffic Impact Study Policy: District policy 7106.1 states that Traffic Impact Studies (TIS) are intended to determine the need for any improvements to the adjacent and nearby transportation system in order to maintain a satisfactory level of service, an acceptable level of safety and the appropriate access provisions for a proposed development. *ITE, Transportation Impact Analyses for Site Development.*

Traffic Impact Studies are generally required when:

- A proposed development or redevelopment of a site will generate 100 or more new peak hour trips; OR
- The added volume is equal to 1,000 vehicles per day; OR
- As required in Table 1 below. (The values in Table 1 are a general guide to determine if a TIS will be required.)

Table 1: Approximate Trigger Values

Land Use Type	Land Use Code	Trigger Value
Residential	210,220,230, 207	100 dwelling units
Retail	814,815,820	35,000 square feet
Office	710, 714, 715, 750, 770	50,000 square feet
Industrial	110, 120, 130, 140	70,000 square feet
Lodging	310, 312, 320	100 rooms
School (K-12)		All

Staff Comments/Recommendations: Although a traffic impact study (TIS) is required for this application it has not been submitted at this time. The applicant's engineer submitted a letter (attachment 3) requesting a temporary variance to the traffic impact study policy, to allow the TIS to be submitted in the near future with conditions set at that time based on the outcome of the study.

Typically, the TIS would need to be submitted and reviewed prior to ACHD's action on a development application. However, staff recognizes the importance of this development to downtown Boise, and the applicant's desire to keep the project moving forward. Therefore, staff recommends a temporary variance of the traffic impact study, as requested by the applicant.

The applicant should be required to construct improvements necessary to mitigate their impacts to the transportation system, as determined by ACHD staff upon completion and acceptance of

the TIS. All improvements should be constructed prior to ACHD and Boise City occupancy sign-off on the building.

3. Condition of Area Roadways

Traffic Count is based on Vehicles Per Hour (VPH)

Roadway	Frontage	Functional Classification	PM Peak Hour Traffic Count	PM Peak Hour Level of Service
Main Street One-Way	135-feet	Minor Arterial	709	Better Than "D"
8 th Street	175-feet	Private	N/A	N/A

* Acceptable level of service for a one-way three-lane minor arterial is "D" (720 VPH) per lane.

4. Average Daily Traffic Count (VDT)

Average daily traffic counts are based on ACHD's most current traffic counts.

- The average daily traffic count for Main Street west of 9th Street was 9,906 on June 29, 2011.

C. Findings for Consideration

1. Access to the Site

Access to the site is proposed to come from the Eastman Parking Garage located west of the site.

2. Main Street

a. Existing Conditions: Main Street is improved with 3-travel lanes, one-dedicated bus lane, vertical curb, gutter, and 8-foot wide sidewalk abutting the site. There is 80-feet of right-of-way for Main Street (40-feet from centerline).

b. Policy

Arterial Roadway Policy: District Policy 7205.2.1 states that the developer is responsible for improving all street frontages adjacent to the site regardless of whether or not access is taken to all of the adjacent streets.

Master Street Map and Typology Policy: District Policy 7205.5 states that the design of improvements for arterials shall be in accordance with District standards, including the Master Street Map and Livable Streets Design Guide. The developer or engineer should contact the District before starting any design.

Street Section and Right-of-Way Width: District Policies 7205.2.1 & 7205.5.1 state that the standard 7-lane street section shall be 96-feet (back-of-curb to back-of-curb) within 120-feet of right-of-way. This width typically accommodates three travel lanes in each direction, a continuous raised or landscaped median with intermittent turn lanes, and safety shoulders.

Street Section and Right-of-Way Width: District Policies 7205.2.1 & 7205.5.1 state that the standard 5-lane street section shall be 72-feet (back-of-curb to back-of-curb) within 96-feet of right-of-way. This width typically accommodates two travel lanes in each direction, a continuous center left-turn lane, and bike lanes on a minor arterial and a safety shoulder on a principal arterial.

Sidewalk Policy: District Policy 7205.5.7 requires a concrete sidewalks at least 5-feet wide to be constructed on both sides of all arterial streets. A parkway strip at least 6-feet wide between the back-of-curb and street edge of the sidewalk is required to provide increased safety and protection of pedestrians. Consult the District's planter width policy if trees are to

be placed within the parkway strip. Sidewalks constructed next to the back-of-curb shall be a minimum of 7-feet wide.

Detached sidewalks are encouraged and should be parallel to the adjacent roadway. Meandering sidewalks are discouraged.

Appropriate easements shall be provided if public sidewalks are placed out of the right-of-way. The easement shall encompass the entire area between the right-of-way line and 2-feet behind the back edge of the sidewalk. Sidewalks shall either be located wholly within the public right-of-way or wholly within an easement.).

Minor Improvements Policy: District Policy 7203.3 states that minor improvements to existing streets adjacent to a proposed development may be required. These improvements are to correct deficiencies or replace deteriorated facilities. Included are sidewalk construction or replacement; curb and gutter construction or replacement; replacement of unused driveways with curb, gutter and sidewalk; installation or reconstruction of pedestrian ramps; pavement repairs; signs; traffic control devices; and other similar items.

ACHD Master Street Map: ACHD Policy Section 3111.1 requires the Master Street Map (MSM) guide the right-of-way acquisition, arterial street requirements, and specific roadway features required through development. This segment of Main Street is designated in the MSM as a Towncenter Arterial with 3-lanes and on-street bike lanes, a 60-foot street section within 90-feet of right-of-way.

- c. **Applicant Proposal:** The applicant hasn't proposed any improvements to Main Street abutting the site.
- d. **Staff Comments/Recommendations:** Main Street in its current configuration with 46-feet of pavement curb to curb contains all the elements of a Towncenter Arterial; as such staff does not recommend any improvements or right-of-way dedication as part of this application.

If the city of Boise desires additional amenities within the pedestrian zone the city should coordinate those requests with the applicant.

3. Private Road- 8th Street

- a. **Private Road Policy:** District Policy 7212.1 states that the lead land use agencies in Ada County establish the requirements for private streets. The District retains authority and will review the proposed intersection of a private and public street for compliance with District intersection policies and standards. The private road should have the following requirements:
 - Designed to discourage through traffic between two public streets,
 - Graded to drain away from the public street intersection, and
 - If a private road is gated, the gate or keypad (if applicable) shall be located a minimum of 50-feet from the near edge of the intersection and a turnaround shall be provided.
- b. **Applicant Proposal:** The applicant has proposed to construction one gated 12-foot wide driveway onto 8th Street to provide access to the trash compactor for the building.
- c. **Staff Comments/Recommendations:** This section of 8th Street is privately owned by Capital City Development Corporation (CCDC). As such staff does not have any specific comments related to 8th Street.

4. Tree Planters

Tree Planter Policy: Tree Planter Policy: The District's Tree Planter Policy prohibits all trees in planters less than 8-feet in width without the installation of root barriers. Class II trees may be allowed in planters with a minimum width of 8-feet, and Class I and Class III trees may be allowed in planters with a minimum width of 10-feet.

5. Landscaping

Landscaping Policy: A license agreement is required for all landscaping proposed within ACHD right-of-way or easement areas. Trees shall be located no closer than 10-feet from all public storm drain facilities. Landscaping should be designed to eliminate site obstructions in the vision triangle at intersections. District Policy 5104.3.1 requires a 40-foot vision triangle and a 3-foot height restriction on all landscaping located at an uncontrolled intersection and a 50-foot offset from stop signs. Landscape plans are required with the submittal of civil plans and must meet all District requirements prior to signature of the final plat and/or approval of the civil plans.

5. Other Access

Main Street is classified as a minor arterial roadway. Other than the access specifically approved with this application, direct lot access is prohibited to this roadway.

D. Site-Specific Conditions of Approval

1. Submit the required traffic impact study to ACHD for review and approval.
2. Construct improvements necessary to mitigate the impacts to the transportation system, as determined by ACHD staff upon completion and acceptance of the TIS. All required public street improvements should be constructed prior to ACHD and Boise City occupancy sign-off on the building.
3. Comply with all Standard Conditions of Approval.

E. Standard Conditions of Approval

1. Any existing irrigation facilities shall be relocated outside of the ACHD right-of-way.
2. Private sewer or water systems are prohibited from being located within the ACHD right-of-way.
3. In accordance with District policy, 7203.6, the applicant may be required to update any existing non-compliant pedestrian improvements abutting the site to meet current Americans with Disabilities Act (ADA) requirements. The applicant's engineer should provide documentation of ADA compliance to District Development Review staff for review.
4. Replace any existing damaged curb, gutter and sidewalk and any that may be damaged during the construction of the proposed development. Contact Construction Services at 387-6280 (with file number) for details.
5. A license agreement and compliance with the District's Tree Planter policy is required for all landscaping proposed within ACHD right-of-way or easement areas.
6. All utility relocation costs associated with improving street frontages abutting the site shall be borne by the developer.
7. It is the responsibility of the applicant to verify all existing utilities within the right-of-way. The applicant at no cost to ACHD shall repair existing utilities damaged by the applicant. The applicant shall be required to call DIGLINE (1-811-342-1585) at least two full business days prior to breaking ground within ACHD right-of-way. The applicant shall contact ACHD Traffic Operations 387-6190 in the event any ACHD conduits (spare or filled) are compromised during any phase of construction.

8. Utility street cuts in pavement less than five years old are not allowed unless approved in writing by the District. Contact the District's Utility Coordinator at 387-6258 (with file numbers) for details.
9. All design and construction shall be in accordance with the ACHD Policy Manual, ISPWC Standards and approved supplements, Construction Services procedures and all applicable ACHD Standards unless specifically waived herein. An engineer registered in the State of Idaho shall prepare and certify all improvement plans.
10. Construction, use and property development shall be in conformance with all applicable requirements of ACHD prior to District approval for occupancy.
11. No change in the terms and conditions of this approval shall be valid unless they are in writing and signed by the applicant or the applicant's authorized representative and an authorized representative of ACHD. The burden shall be upon the applicant to obtain written confirmation of any change from ACHD.
12. If the site plan or use should change in the future, ACHD Planning Review will review the site plan and may require additional improvements to the transportation system at that time. Any change in the planned use of the property which is the subject of this application, shall require the applicant to comply with ACHD Policy and Standard Conditions of Approval in place at that time unless a waiver/variance of the requirements or other legal relief is granted by the ACHD Commission.

F. Conclusions of Law

1. The proposed site plan is approved, if all of the Site-Specific and Standard Conditions of Approval are satisfied.
2. ACHD requirements are consistent with applicable federal, state and local laws.

G. Attachments

1. Vicinity Map
2. Site Plan
3. Request for Temporary Variance
4. Utility Coordinating Council
5. Development Process Checklist
6. Request for Reconsideration Guidelines

Request for Reconsideration of Commission Action

1. **Request for Reconsideration of Commission Action:** A Commissioner, a member of ACHD staff or any other person objecting to any final action taken by the Commission may request reconsideration of that action, provided the request is not for a reconsideration of an action previously requested to be reconsidered, an action whose provisions have been partly and materially carried out, or an action that has created a contractual relationship with third parties.

- a. Only a Commission member who voted with the prevailing side can move for reconsideration, but the motion may be seconded by any Commissioner and is voted on by all Commissioners present.

If a motion to reconsider is made and seconded it is subject to a motion to postpone to a certain time.

- b. The request must be in writing and delivered to the Secretary of the Highway District no later than 3:00 p.m. on the day prior to the Commission's next scheduled regular meeting following the meeting at which the action to be reconsidered was taken. Upon receipt of the request, the Secretary shall cause the same to be placed on the agenda for that next scheduled regular Commission meeting.
- c. The request for reconsideration must be supported by written documentation setting forth new facts and information not presented at the earlier meeting, or a changed situation that has developed since the taking of the earlier vote, or information establishing an error of fact or law in the earlier action. The request may also be supported by oral testimony at the meeting.
- d. If a motion to reconsider passes, the effect is the original matter is in the exact position it occupied the moment before it was voted on originally. It will normally be returned to ACHD staff for further review. The Commission may set the date of the meeting at which the matter is to be returned. The Commission shall only take action on the original matter at a meeting where the agenda notice so provides.
- e. At the meeting where the original matter is again on the agenda for Commission action, interested persons and ACHD staff may present such written and oral testimony as the President of the Commission determines to be appropriate, and the Commission may take any action the majority of the Commission deems advisable.
- f. If a motion to reconsider passes, the applicant may be charged a reasonable fee, to cover administrative costs, as established by the Commission.



Dennis Doan
Chief

City Hall West
333 N. Mark Stall Place
Boise, Idaho 83704-0644

Phone
208/570-6500

Fax
208/570-6586

TDD/TTY
800/377-3529

Web
www.cityofboise.org/fire



Mayor
David H. Bieter

City Council
President
Maryanne Jordan

Council Pro Tem
David Eberle

Elaine Clegg
Lauren McLean
TJ Thomson
Ben Quintana

Fire Department

September 5, 2013

Dave Abo
PDS - Planning

Re: Preliminary/Final Plat – Eight and Main Condominiums; SUB13-00040
800 W. Main Street

Dear Dave,

This is a request for a preliminary/final plat for a condominium project.

The Boise Fire Department has reviewed and can approve the application subject to compliance with all of the following code requirements and conditions of approval. Any deviation from this plan is subject to Fire Department approval. Please note that unless stated otherwise, this memo represents the requirements of the International Fire Code (IFC) as adopted and amended by Ordinance 6308.

Comments:

1. None

General Requirement:

Specific building construction requirements of the International Building Code, International Fire Code, International Residential Code and Boise City Code will apply. However, these provisions are best addressed by a licensed Architect at building permit application.

Please feel free to have the applicant contact Romeo Gervais at 570-6567 if they have any questions.

Regards,

Romeo P. Gervais, P.E.
Deputy Chief – Fire Marshal
Boise Fire Department